

1-100SL Quarter-Turn PrA L18 SNAP-LINE

Tool-less installation, Tool operable, IP65



Product Notes:

- Type A see Product System 3-010. Additional snap-in extensions can be used for cutouts type B and C
- RH and LH application
- Pre-assembled Quarter-Turn can be installed in cutout even with 3-point cam attached
- Water and dust tight according to IP65, DIN EN 60529
- Grounding achieved with grounding clip
- Optional pre-assembly by DIRAK including 3-point cam
- **NOTE: H-dimension of the cam must be greater than 16mm (5/8")**

Material:

- **Housing:** PA, Black
- **Bottom:** Zinc Die, Zinc Plated
- **Wings:** Sintered Steel, Zinc Plated
- **Grounding clip:** Stainless Steel
- **Insert:** See b)
- **Cams:** See c) and c1)
- **O-Rings:** NBR, Black

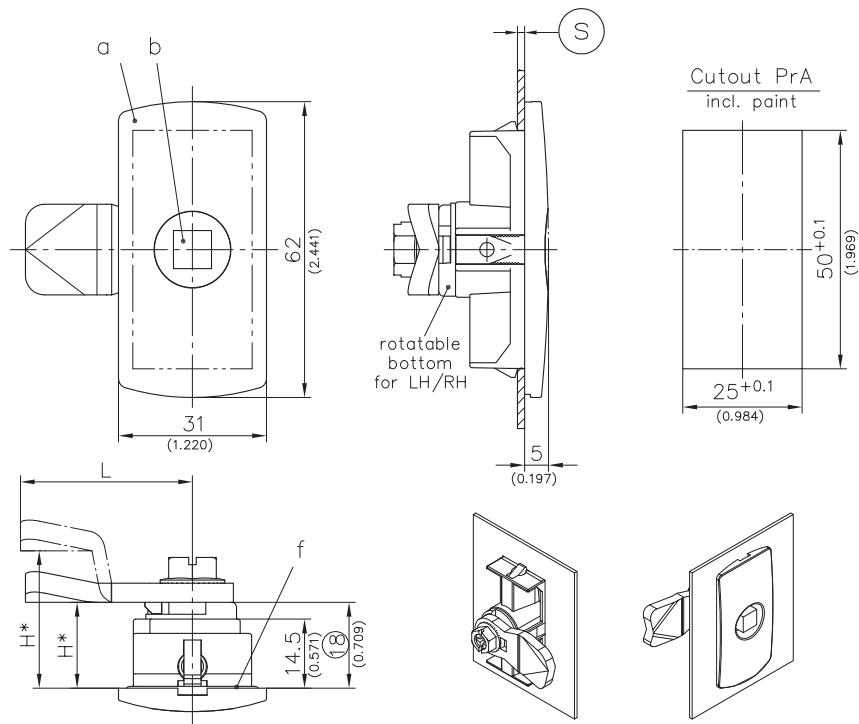

* Attention: $\geq H16$ (5/8")

a) Housing with Wings, O-ring and rotatable bottom			
Clamping Range [Ⓢ]	With Grounding Clip	Without Grounding Clip	See Page
0.8 - 1.5	408-9301.00-00015	408-9302.00-00015	
1.3 - 2.0	408-9301.00-00020	408-9302.00-00020	
1.8 - 2.5	408-9301.00-00025	408-9302.00-00025	
2.3 - 3.0	408-9301.00-00030	408-9302.00-00030	
2.8 - 3.5	408-9301.00-00035	408-9302.00-00035	
b) Inserts			01.42, 01.98, 01.99
c) Cams			01.42, 01.101, 01.102
c1) 3-point cams			01.101
d) Grounding clip (included in 408-9301)		200-1104.93	
Optional:			
Water and dust tight according to IP65 by:			
e) O-ring for insert	200-1001.00-00000	200-1001.00-00000	
f) O-ring for housing	208-1804.00-00000	208-1804.00-00000	
i) Cutout			03.07

1-100SL Quarter-Turn PrA L18 SNAP-LINE

Tool-less installation, Tool operable, IP65

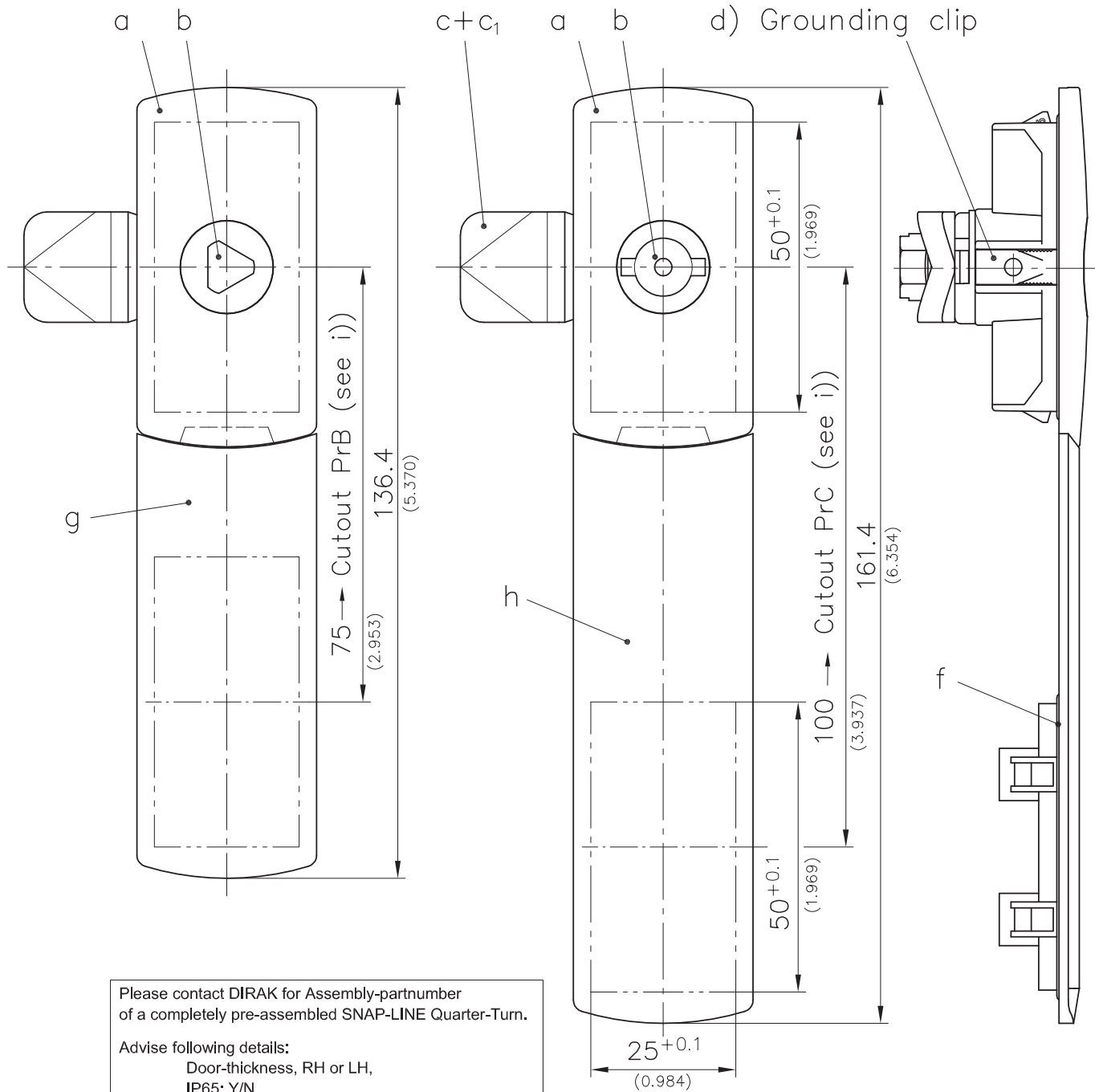

Please contact DIRAK for Assembly-partnumber of a completely pre-assembled SNAP-LINE Quarter-Turn.

Advise following details:
 Door-thickness, RH or LH,
 IP65: Y/N,
 Grounding: Y/N,
 Insert, cam.

Please note, that we also can pre-assemble a 3-point can.

	Cutout	Part No.	See Page
g) Escutcheon short	Type B (75)	208-0523.03	
h) Escutcheon	Type C (100)	208-0522.03	
f) O-ring for housing		208-1804.00	
i) Cutout			03.07
Cover for cutout			03.28